



**LOWER MANUHERIKIA VALLEY**

**MINI HYDROPOWER STUDY**

(SUPPLEMENTS DETAILED CONCEPT STUDY)

**MANUHERIKIA IRRIGATION CO-OPERATIVE SOCIETY LTD**



# Lower Manuherikia Valley Water Resources Study

## Mini Hydropower Station Prefeasibility Study (Supplements Detailed Concept Study)

### Manuherikia Irrigation Co-operative Society Ltd

Prepared By

Marq Redeker  
Work Group Manager,  
Rivers and Coastal Engineering

Opus International Consultants Limited  
Environmental  
Level 9, Majestic Centre, 100 Willis Street  
PO Box 12 003, Wellington 6144,  
New Zealand

Reviewed By

Lambert Anderson  
Manager,  
Water Resources

Telephone: +64 4 471 7000  
Facsimile: +64 4 499 3699

Date: March 2010  
Reference: 3-50705.00  
Status: Final Draft

## Contents

|          |   |           |
|----------|---|-----------|
| <b>1</b> | <b>Introduction</b> .....                             | <b>1</b>  |
| <b>2</b> | <b>Hydrological analysis</b> .....                    | <b>3</b>  |
|          | 2.1 Analysis of the flow record .....                 | 3         |
|          | 2.2 Consideration of ecological flows .....           | 5         |
| <b>3</b> | <b>Estimation of power and energy output</b> .....    | <b>6</b>  |
| <b>4</b> | <b>Turbine technology</b> .....                       | <b>8</b>  |
|          | 4.1 Selection of appropriate turbine technology ..... | 8         |
|          | 4.2 Crossflow turbine.....                            | 8         |
|          | 4.3 Francis turbine.....                              | 11        |
| <b>5</b> | <b>Economic feasibility assessment</b> .....          | <b>12</b> |
| <b>6</b> | <b>Conclusions</b> .....                              | <b>13</b> |
| <b>7</b> | <b>References</b> .....                               | <b>14</b> |

## 1 Introduction

This Mini Hydropower Station Prefeasibility Study supplements our Detailed Concept Study. As part of a water resource investigation of the Lower Manuherikia Valley, the feasibility of a mini hydropower station, using an existing water take and use consent, is being considered.

Otago Regional Council (ORC) resource consent no. 2001.505 permits water abstraction to a maximum of 2.83 m<sup>3</sup>/s (244,512 m<sup>3</sup>/day) on the Manuherikia River near Chatto Creek, about 19.5 km northeast of Alexandra (Figure 1), for the purpose of irrigation for a term expiring 1 October 2021.



Figure 1: Aerial overview

Water was formerly conveyed along an old race on the north side of the gorge (Figure 2).



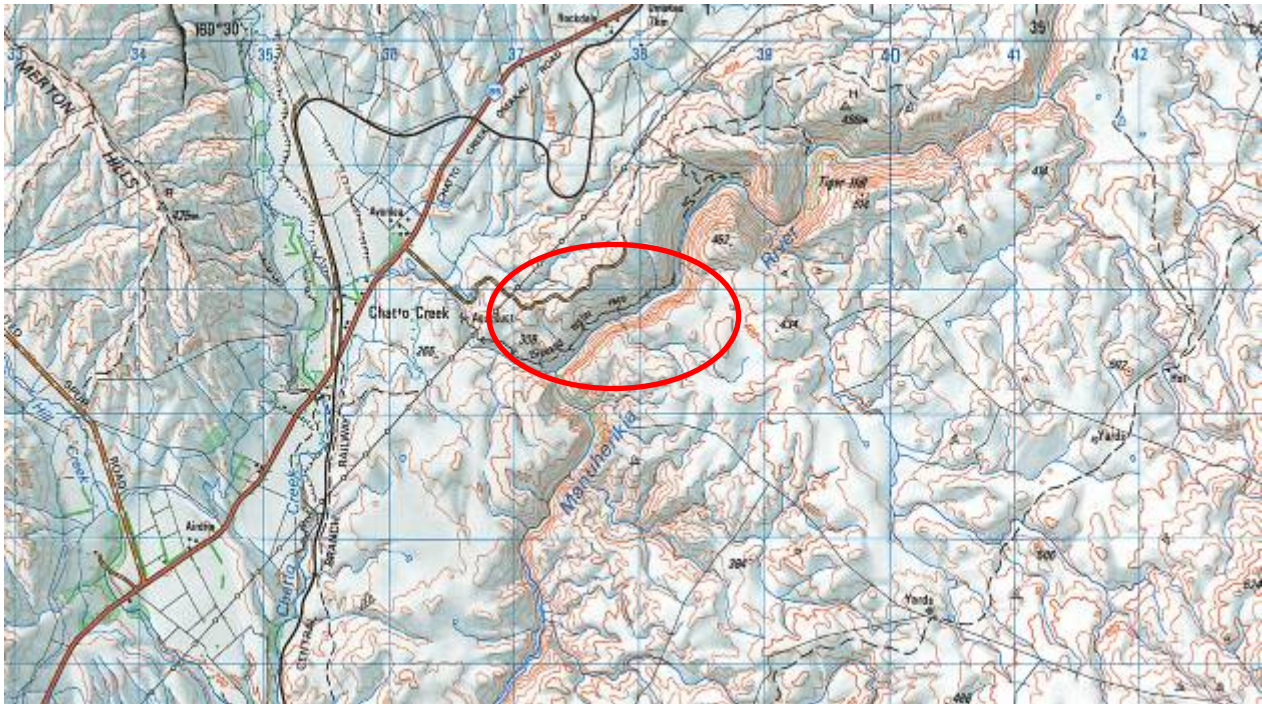
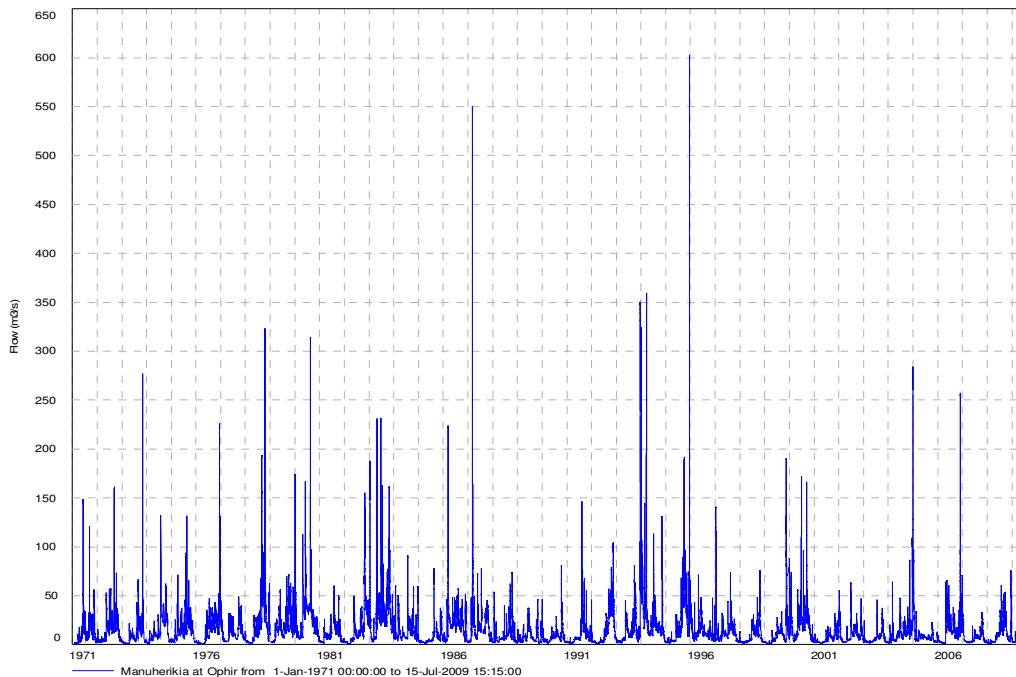

Figure 2: Topographic map

According to an initial investigation using a small GPS unit, Gary Kelliher from the Manuherikia Irrigation Co-operative Society suggests there is about 40 m of head from the old disused race to the river level that could be utilised for hydropower generation.

## 2 Hydrological Analysis

### 2.1 Analysis of the Flow Record



*Figure 3: Time series plot of the record*

Initially, a hydrological analysis was performed to assess the temporal and quantitative availability of water for hydropower generation in the Manuherikia River at the site in question.

The most appropriate and relevant hydrometric site for this analysis was Manuherikia @ Ophir.

Although some stage data were initially recorded from 10 October 1919, the record stops in 1931. There is no rating information for this period and therefore, the data cannot be converted to flow. The flow record only begins in 1971, and so the analysis detailed below is based on approximately 38 years of data (Figure 3).

The following graph and table illustrate the flow distribution of the Manuherikia River @ Ophir (values in  $\text{m}^3/\text{s}$ ).

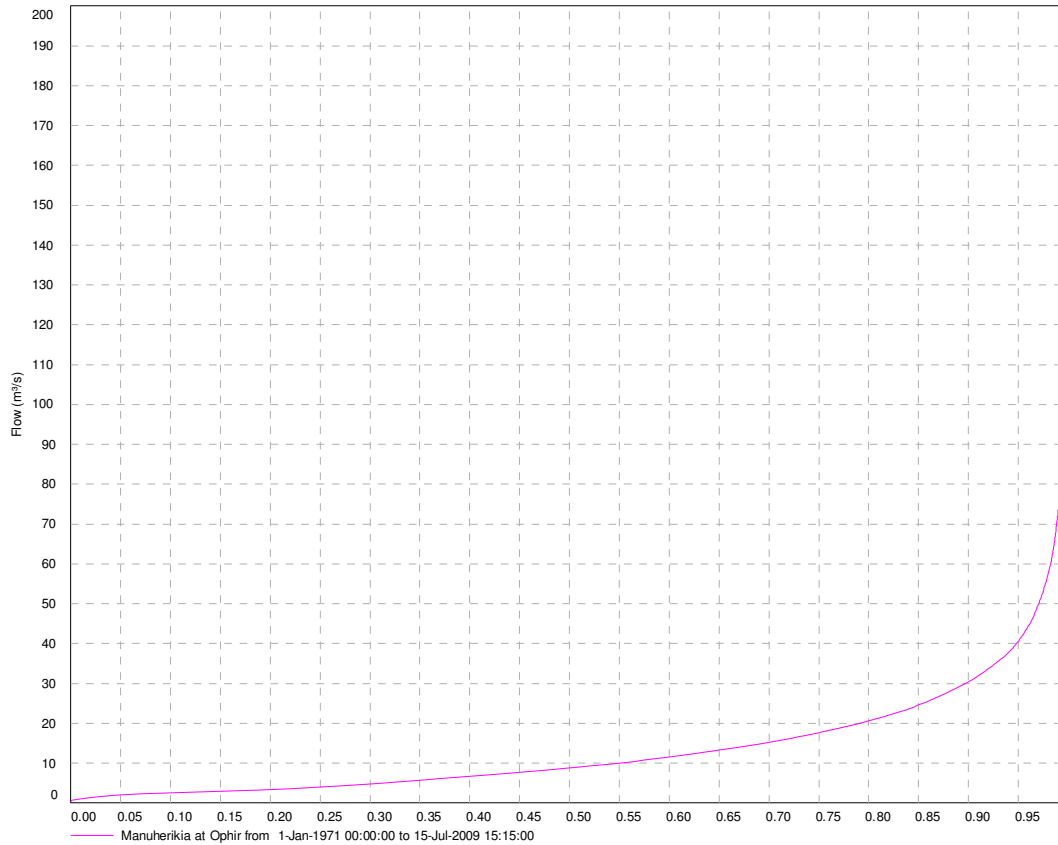

Figure 4: Graph of the flow distribution of the Manuherikia River

|     | 0     | 1    | 2    | 3    | 4    | 5    | 6    | 7    | 8    | 9    |
|-----|-------|------|------|------|------|------|------|------|------|------|
| 0   | 602.4 | 73.8 | 57.5 | 49.8 | 44.3 | 40.5 | 37.8 | 35.6 | 33.7 | 31.9 |
| 10  | 30.4  | 29   | 27.8 | 26.6 | 25.5 | 24.5 | 23.6 | 22.8 | 22.1 | 21.3 |
| 20  | 20.6  | 20   | 19.3 | 18.8 | 18.2 | 17.6 | 17.1 | 16.6 | 16.1 | 15.6 |
| 30  | 15.2  | 14.7 | 14.3 | 14   | 13.6 | 13.2 | 12.8 | 12.5 | 12.1 | 11.8 |
| 40  | 11.5  | 11.2 | 10.9 | 10.6 | 10.3 | 10   | 9.8  | 9.6  | 9.3  | 9.1  |
| 50  | 8.8   | 8.6  | 8.4  | 8.1  | 7.9  | 7.7  | 7.5  | 7.3  | 7.1  | 6.9  |
| 60  | 6.7   | 6.5  | 6.3  | 6.1  | 5.9  | 5.7  | 5.5  | 5.3  | 5.1  | 4.9  |
| 70  | 4.8   | 4.6  | 4.4  | 4.3  | 4.1  | 4    | 3.9  | 3.7  | 3.6  | 3.4  |
| 80  | 3.3   | 3.2  | 3.2  | 3.1  | 3    | 2.9  | 2.8  | 2.8  | 2.7  | 2.6  |
| 90  | 2.5   | 2.4  | 2.4  | 2.3  | 2.1  | 2    | 1.8  | 1.6  | 1.3  | 1    |
| 100 | 0.3   |      |      |      |      |      |      |      |      |      |

Table 1: Table of the flow distribution of the Manuherikia River

The following table is a summary of the analysis of the flow record (values in m<sup>3</sup>/s).

| Min | Max   | Mean | Std Dev | L.Q. | Median | U.Q. |
|-----|-------|------|---------|------|--------|------|
| 0.3 | 602.4 | 13.8 | 17.5    | 4.0  | 8.8    | 17.6 |

Table 2: Summary of the flow record

It should be noted that a number of consents for water have been operative upstream of the recorder since the 1890s. It has been assumed, at the level of this study, that the effect of these consents on the flow regime of the river is already incorporated into the record from the Manuherikia @ Ophir. Therefore, no attempt has been made to naturalise the flow regime. This analysis may be required at a later stage of consideration of this proposal.

## 2.2 Consideration of Ecological Flows

Most likely a resource consent change would be required to permit hydropower generation. In this context, it is presumed that conditions would be imposed to establish ecological / minimum (environmental) flows ( $Q_{\min}$ ) to provide for in-stream values in the river downstream of the abstraction point and at which the abstraction of water ceases.

ORC's Regional Water Plan sets minimum flows for the purpose of restricting primary allocation takes of water in specific catchments or catchment areas (identified in Schedule 2A) in Section 6.4.3. However, in the Manuherikia River, minimum flows are only defined for the catchment upstream of Ophir ( $Q_{\min} = 820$  l/s). For existing takes outside Schedule 2A catchments, Section 6.4.4 states that "minimum flows for the purpose of restricting primary allocation takes of water, will be determined after investigations have established the appropriate minimum flows ..."

Therefore, for the purpose of this study, minimum flows were considered according to the MfE "Proposed National Environmental Standard on Ecological Flows and Water Levels" (2008). For rivers and streams with mean flows greater than 5 m<sup>3</sup>/s, a minimum flow of 80% of the mean annual low flow (MALF) is proposed as an interim limit.

The 7-day MALF for the site in question is 2.0 m<sup>3</sup>/s. Therefore, 80% of the MALF, potentially used as the minimum flow, is 1.6 m<sup>3</sup>/s.

The flow distribution of the Manuherikia River minus the minimum flow of 1.6 m<sup>3</sup>/s was analysed and is illustrated in the following table and graph.

|    | 0     | 1    | 2    | 3    | 4    | 5    | 6    | 7    | 8    | 9    |
|----|-------|------|------|------|------|------|------|------|------|------|
| 0  | 600.8 | 72.2 | 56.0 | 48.2 | 42.7 | 39.0 | 36.2 | 34.0 | 32.1 | 30.3 |
| 10 | 28.8  | 27.4 | 26.2 | 25.1 | 23.9 | 22.9 | 22.1 | 21.2 | 20.5 | 19.7 |
| 20 | 19.0  | 18.4 | 17.7 | 17.2 | 16.6 | 16.0 | 15.5 | 15.0 | 14.5 | 14.0 |
| 30 | 13.6  | 13.2 | 12.7 | 12.4 | 12.0 | 11.6 | 11.3 | 10.9 | 10.5 | 10.2 |
| 40 | 9.9   | 9.6  | 9.3  | 9.0  | 8.7  | 8.4  | 8.2  | 8.0  | 7.7  | 7.5  |
| 50 | 7.3   | 7.0  | 6.8  | 6.6  | 6.3  | 6.1  | 5.9  | 5.7  | 5.5  | 5.3  |
| 60 | 5.1   | 4.9  | 4.7  | 4.5  | 4.3  | 4.1  | 3.9  | 3.7  | 3.5  | 3.3  |
| 70 | 3.2   | 3.0  | 2.8  | 2.7  | 2.5  | 2.4  | 2.3  | 2.1  | 2.0  | 1.9  |



|     |     |     |     |     |     |     |     |     |     |     |
|-----|-----|-----|-----|-----|-----|-----|-----|-----|-----|-----|
| 80  | 1.7 | 1.6 | 1.6 | 1.5 | 1.4 | 1.3 | 1.2 | 1.2 | 1.1 | 1.0 |
| 90  | 0.9 | 0.8 | 0.8 | 0.7 | 0.5 | 0.4 | 0.3 | 0.2 | 0.1 | 0.1 |
| 100 | 0.0 |     |     |     |     |     |     |     |     |     |

Table 3: Table of the flow distribution of the Manuherikia River minus minimum flow of 1.6 m<sup>3</sup>/s

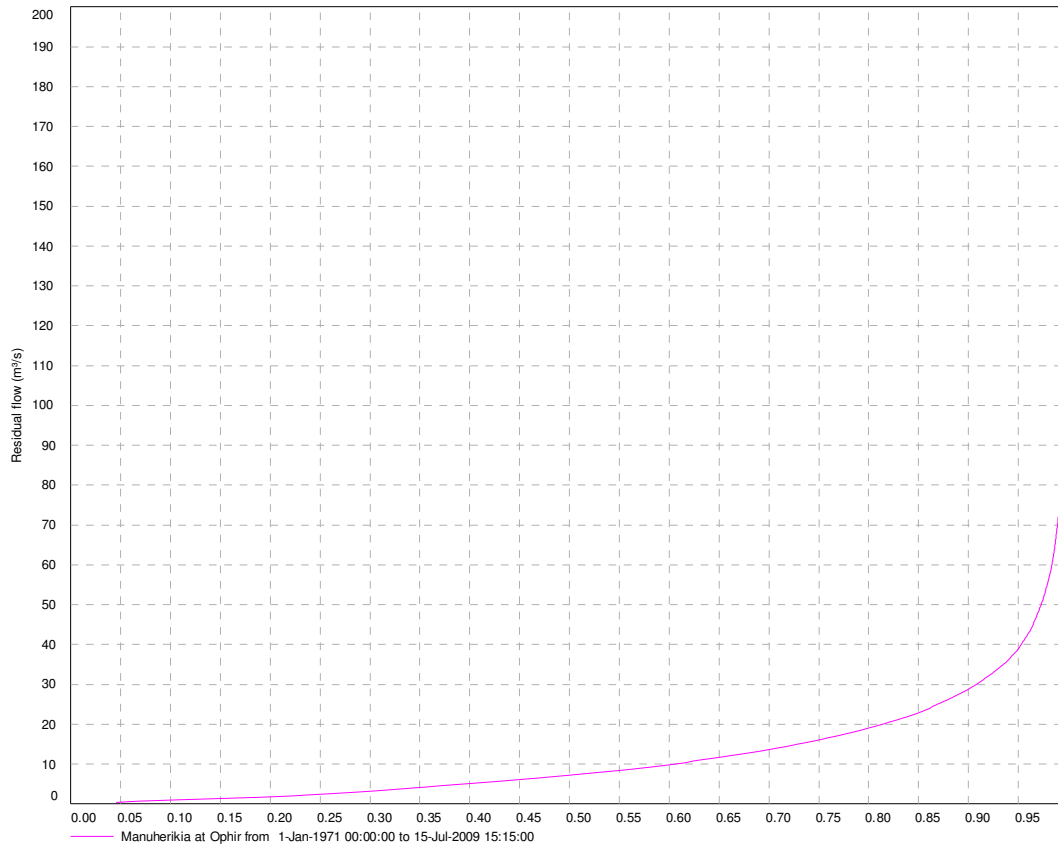

Figure 5: Graph of the flow distribution of the Manuherikia River minus minimum flow of 1.6 m<sup>3</sup>/s

Note that the maximum consented take of 2.83 m<sup>3</sup>/s would be available approximately 72% of the time.

A summary of the adjusted flow record is provided in the following Table 4.

| Min | Max   | Mean | Std Dev | L.Q. | Median | U.Q. |
|-----|-------|------|---------|------|--------|------|
| 0   | 600.8 | 12.2 | 17.5    | 2.40 | 7.2    | 16.0 |

Table 4: Summary of the adjusted flow record (incl. minimum flow)

### 3 Estimation of Power and Energy Output

The maximum capacity (power output)  $P_{el,max}$  of a hydropower plant can be determined according to the following equation:

$$P_{el,max} = \eta_{total} * \rho * g * H * Q \quad (\text{kW})$$

with:  $\eta_{total}$ : efficiency as f(Q,H) with:  $\eta_{total} = \eta_T * \eta_{GU} * \eta_{Gen}$   
 $\eta_T$  turbine efficiency  
 $\eta_{GU}$  gear unit efficiency  
 $\eta_{Gen}$  generator efficiency  
 $\rho$  = density of water (kg/m<sup>3</sup>)  
 $g$  = acceleration of gravity (9.81 m/s<sup>2</sup>)  
 $H$  = head (difference in height between the inlet and outlet surfaces)  
 $Q$  = flow

For the site in question, the potential maximum power output is estimated to be around **860 kW**, based on following assumptions:

- common maximum turbine efficiencies of between 85% and 91%
- common generator efficiencies of between 91% and 95%
- common gear unit efficiencies of between 96% and 98%
- head of 40 m (no consideration of potential hydraulic losses)
- flow of 2.83 m<sup>3</sup>/s (as currently consented)

Typically, power generation in a run-of-river hydropower plant varies on an hourly or daily basis according to several factors, such as:

- river flow (or flow available for hydropower generation),
- head (depending on the prevailing up- and downstream water levels), and
- specific turbine, gear unit and generator efficiencies (depending on the specific loading conditions).

The total annual energy output is the product of the daily generations. The maximum output can seldom be achieved continuously over an entire year.

Based on the (historic) flow distribution of the Manuherikia River including a potential minimum flow of 1.6 m<sup>3</sup>/s (Section 2.2), the potential total energy output of a mini hydropower plant is estimated to be around **6.1 - 6.4 M kWh** per year. A spreadsheet-type estimation is attached as Appendix 1.

This converts to a favourable capacity factor<sup>1</sup> of 0.81 to 0.85.

<sup>1</sup> The 'Capacity factor' is a ratio summarising how hard a turbine is working, expressed as follows:  
Capacity factor (%) = Energy generated per year / (Installed capacity (kW) x 8760 hours/year)

## 4 Turbine Technology

### 4.1 Selection of Appropriate Turbine Technology

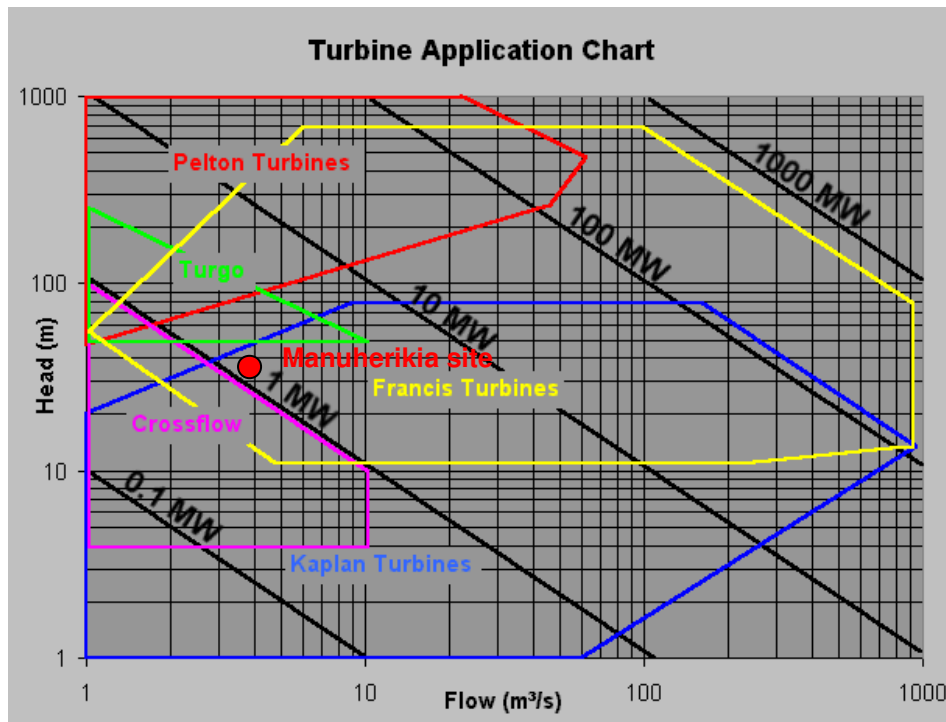

Figure 6: Turbine application chart (© Wikipedia)

The selection of appropriate turbine, mechanical and electrical equipment typically forms part of a feasibility study and initial design. However, for the purpose of this study an initial indication of appropriate turbine technology is given below.

Turbine selection is commonly based on the available head and flow rate. In general, impulse turbines are used for high head sites, and reaction turbines are used for low head sites. Figure 6 illustrates the applicability of specific turbine types depending on head and flow.

Two turbine technologies are appropriate for the Manuherikia site:

- Crossflow turbine
- (Compact) Francis turbine

### 4.2 Crossflow Turbine

A crossflow turbine consists of a cylindrical water wheel or runner with a horizontal shaft, composed of numerous blades, arranged radially and tangentially (Figure 7). A blade is made in a part-circular cross-section.

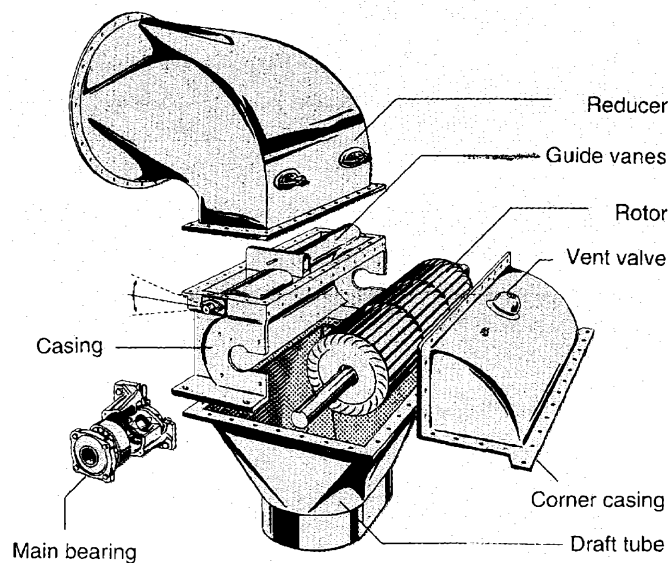

Figure 7: Arrangement of a crossflow turbine (© Ossberger)

Unlike most water turbines which have axial or radial flows, in a crossflow turbine, the water passes through the turbine transversely, or across the turbine blades (Figure 8). The regulating unit, shaped like a vane or tongue, varies the cross-section of the flow. As with a waterwheel, the water is admitted at the turbine's edge. After passing the runner, it leaves on the opposite side. Going through the runner twice provides additional efficiency. When the water leaves the runner, it also helps clean the runner of small debris and pollution.

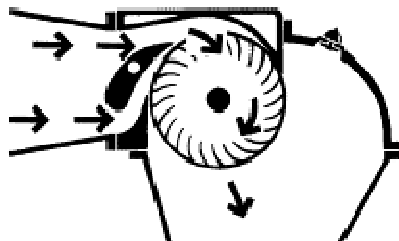

Figure 8: Horizontal inflow crossflow turbine (© Ossberger)

Crossflow turbines are often constructed as two turbines of different capacity that share the same shaft (Figure 7). The turbine wheels are the same diameter, but different lengths to handle different volumes at the same pressure. The subdivided wheels are usually built with volumes in ratios of 1:2. The subdivided regulating unit (the guide vane system in the turbine's upstream section) provides flexible operation, with  $\frac{1}{3}$ ,  $\frac{2}{3}$  or 100% output, depending on the flow.

The cross-flow turbine is a low-speed machine.

The peak efficiency of a crossflow turbine is somewhat less than a Kaplan, Francis or Pelton turbine. However, the crossflow turbine has a flat efficiency curve under varying load. With a split runner and turbine chamber, the turbine maintains its efficiency while the flow and load vary from  $\frac{1}{6}$  to the maximum (Figure 9).

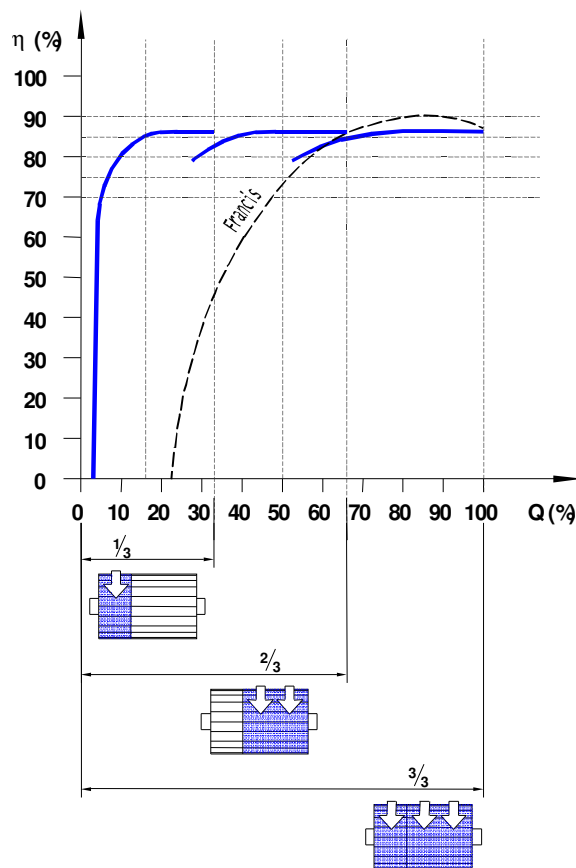

Figure 9: Efficiency curve of a crossflow turbine (© Ossberger)

Particularly with small run-of-the-river plants, the flat efficiency curve yields better annual performance than other turbine systems, as small rivers' flows can vary significantly throughout the year, like in the current case. In principle, the efficiency of a turbine determines whether electricity is produced during the periods when rivers have lower flows. If the turbines used have high peak efficiencies, but behave poorly at partial load, less annual performance is obtained than with turbines that have a flat efficiency curve.

Due to its excellent behaviour with partial loads, the crossflow turbine is well-suited to unattended electricity production. Its simple construction makes it easier to maintain than other turbine types; only two bearings must be maintained, and there are only three rotating elements. The mechanical system is simple, so repairs can usually be performed by local mechanics.

In general crossflow turbine are comparatively cheap. Low operating costs are obtained with the turbine's relatively simple construction.

### 4.3 Francis Turbine

Francis turbines are the most common water turbine in use today. They operate in a head range of ten meters to several hundred meters.

A Francis turbine is essentially a modified form of propeller turbine in which water flows radially inwards into runner and is turned to emerge axially. For medium-head schemes, the runner is most commonly mounted in a spiral casing with internal adjustable guide vanes.

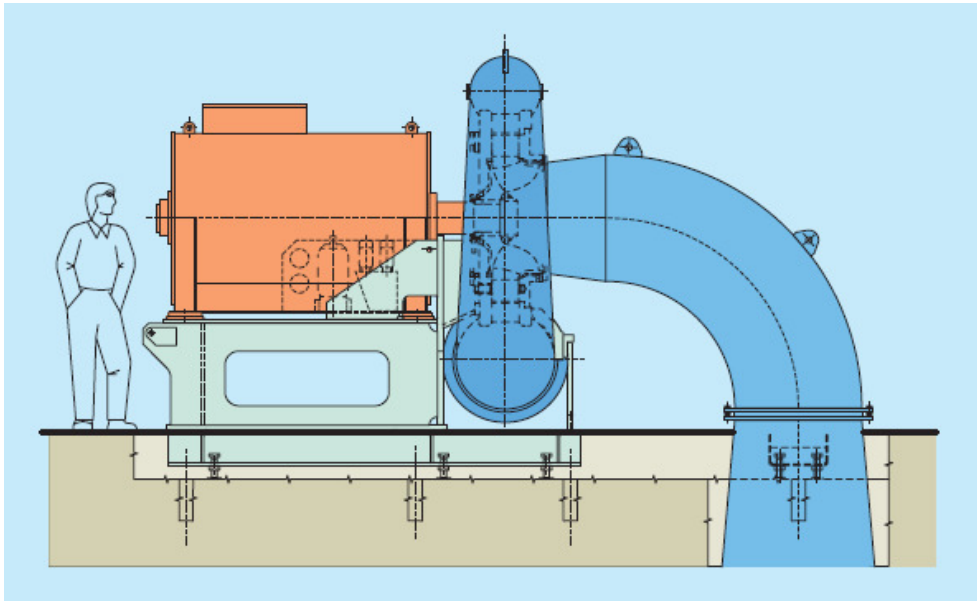

Figure 10: Arrangement of a compact Francis turbine (© VATech)

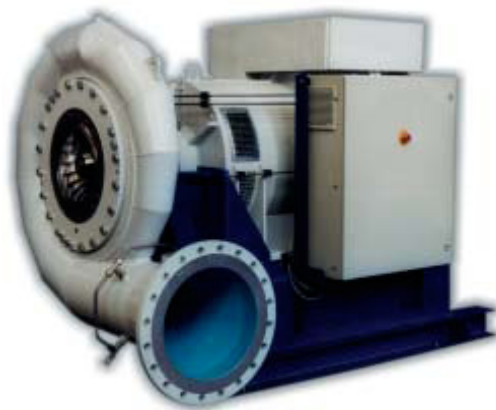

Figure 11: Picture of a compact Francis turbine (© VATech)

For smaller units, Francis turbines are nowadays available as so-called Compact Francis turbines (Figure 10 and 11). The turbine-generator units are shop-tested and cabled, and delivered as a complete assembly with control oil system ready for immediate installation. This concept greatly simplifies foundation preparations, thus reducing construction costs and drastically cutting erection times.



Runner development for Compact Francis turbines are based on standard sizes with modular components, still allowing customized solutions.

## 5 Economic Feasibility Assessment

Economic feasibility assessments require preliminary estimates of project costs. Within the scope of this study, a preliminary cost estimate, in particular of potential physical works expenditure, was not feasible. However, a different approach was pursued to investigate the principle economic feasibility of a hydropower station on the Manuherikia River near Chatto Creek further.

In general, hydropower plants are long-term projects, both in terms of financial lifetime (amortization period) and effective lifetime (availability until their obsolescence). From an economic viewpoint, a hydropower plant differs for example from a conventional thermal plant because its initial investment cost per kW is much higher but the operating costs are very low. On the basis of experience over several decades, hydroelectric plants can usually be credited with an effective lifetime substantially longer than their financial lifetime, i.e. the residual value will usually be positive.

Investors regularly anticipate short amortization periods. However amortization periods of hydropower projects commonly range from 20 to 40 years depending on various aspects such as:

- the nature of the project (e.g. new construction or rehabilitation),
- local conditions (topography, geology, site access / infrastructure, grid distance etc.),
- legal framework (consent requirements and duration of consents),
- operational conditions (level of attendance, revisions and running costs (OPEX) )
- financial conditions (discount rate and available proprietary (investment) capital),
- energy use (grid-connect (so-called 'embedded generation') vs. stand-alone / self-supply),
- specific compensation (depending on individual contractual arrangements, e.g. with an energy company), and
- duration of price-fixing and/or electricity price alterations / variations.

Amortization periods below 20 years are usually only achieved with stand-alone/self-supply projects (i.e. where as much of the electricity as possible is consumed on site, i.e. displacing electricity that would otherwise be bought in from the grid, and therefore provides a higher level of remuneration) or in countries that subsidise renewable energies.

Based on the potential energy output of a mini hydropower plant (Section 3), a dynamic amortization calculation was performed to identify maximum investment costs that would allow a project amortization period of up to 30 years. The underlying assumptions are:

- The project is fully outside financed, i.e. no proprietary capital.
- Annual energy output of 6.2 M kWh.
- Annual operation and maintenance costs of around NZ\$ 20,000.
- Embedded generation.

An example calculation is attached in Appendix 2. A sensitivity analysis was undertaken for different discount rates (5 - 10%) and specific compensations (4 - 6 ct/kWh). Figure 12 illustrates the results of this analysis.

As indicated above, hydropower schemes are individually designed to match the site-specific conditions. Accordingly, the costs of schemes are very much site-specific. In general, specific investment costs of hydropower projects are known to have a comparatively large band and reduce with increasing head.

Internationally the specific investment costs of small hydroelectric plants reported by implementing agencies and consultants range from 3,500 to about 15,000 US\$/kW (converted: 5,000 - 21,500 NZ\$/kW). A report prepared by Parsons Brinckerhoff Associates for the NZ Electricity Commission in 2005 indicates specific investment costs of 5,500 to 7,600 NZ\$/kW for small hydroelectric plants with capacities between 2 and 5 MW in the South Island.

Applying specific investment costs of 7,000 to 9,000 NZ\$/kW to the project in question, this yields investment costs in the order of NZ\$ 6.02 to 7.74 M. These are higher than the maximum investment costs identified in the sensitivity analysis above, which initially indicates that an embedded generation project might only be financially viable under specific conditions and that a self-supply scenario should be considered further.

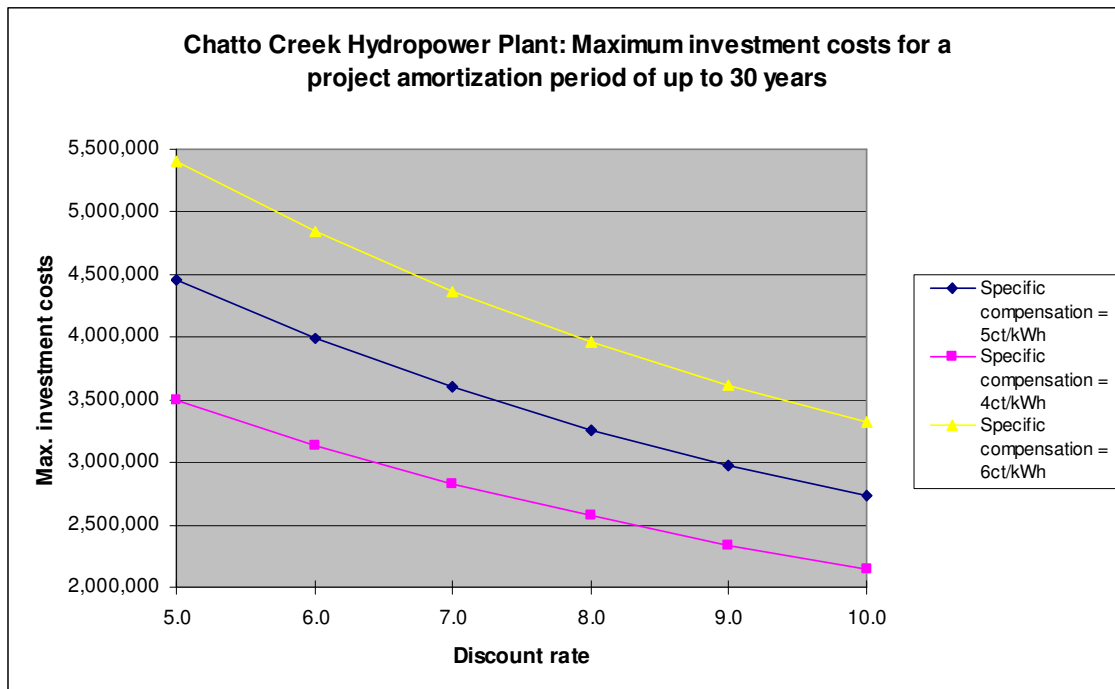

Figure 12: Maximum investment costs analysis for different discount rates and specific compensations

## 6 Conclusions

From a technical point of view, a mini hydropower station on the Manuherikia River near Chatto Creek seems feasible. However, a more detailed assessment is required to determine the technical feasibility. The scope should include:

- condition assessment of the existing assets (e.g. water abstraction structure, old race etc.) that would be utilized for hydropower generation;

- identification of potential location and accessibility of forebay (tank), penstock, powerhouse and tailrace;
- check of the maximum hydraulic capacity of the old race and leakages
- initial geotechnical investigations;
- selection and initial sizing of appropriate turbine and generator technology, penstock and associate mechanical equipment;
- initial structural design of a powerhouse and tailrace;
- check of grid availability and distance, and its electrical specifications; and
- estimate of capital costs.

The initial economic assessment based on the potential annual output and common investment costs indicates that a mini hydropower development on the Manuherikia River near Chatto Creek may only be viable under certain conditions. Therefore, a more precise economic assessment based on a sound estimate of capital costs that take into account the local conditions and existing / usable assets is highly recommended. The sensitivity analysis also denotes that the economic viability depends highly on the financial conditions (interest / discount rates) and specific compensation, i.e. potential revenue. It also shows that a short amortization period is unrealistic. Within the scope of an expanded feasibility study, it is therefore recommended to:

- investigate the energy use (embedded generation vs. self-supply (e.g. to offset irrigation scheme pumping costs), or a mix of the two) further;
- make initial contacts to appropriate buyers (e.g. Contact Energy, Pioneer or Trustpower); and
- determine the planning framework (resource consent change, consent duration, consent conditions and possibility of an increase of abstraction volume).

## 7 References

British Hydropower Association (2005) "A guide to UK mini-hydro developments"

European Small Hydropower Association (2004) "Guide on How to Develop a Small Hydropower Plant"

Ministry for the Environment (2008) "Proposed National Environmental Standard on Ecological Flows and Water Levels", Discussion Document

Ministry for the Environment (2008) "Draft Guidelines for the Selection of Methods to Determine Ecological Flows and Water Levels"

Otago Regional Council (2006) "Regional Plan: Water"

Parsons Brinckerhoff Associates (2005) "Hydro-Electric Potential in New Zealand". Report prepared for the Electricity Commission

[www.ossberger.de/cms/en/home/](http://www.ossberger.de/cms/en/home/)

[www.andritz.com/hydro-media-media-center-compact-hydro-francis\\_en\\_1\\_.pdf](http://www.andritz.com/hydro-media-media-center-compact-hydro-francis_en_1_.pdf)

## Appendix 1

## Hydropower generation

|                                |                                     |                   |
|--------------------------------|-------------------------------------|-------------------|
| Project:                       | Manuherikia River near Chatto Creek |                   |
| Turbine type:                  | Crossflow turbine                   |                   |
| Flow QT:                       | 2.83                                | m <sup>3</sup> /s |
| Generation commences: 16% QT = | 0.45                                | m <sup>3</sup> /s |
| Generator efficiency           | 93                                  | %                 |
| Gear unit efficiency:          | 97                                  | %                 |
| Standstill:                    | 5                                   | %                 |

| Days | $\Delta$<br>days | Q <sub>Manuherikia</sub> | Q <sub>Turbine</sub> | Turbine<br>loading | Turbine<br>efficiency | Head | Total<br>efficiency | Power<br>output | Energy<br>output |
|------|------------------|--------------------------|----------------------|--------------------|-----------------------|------|---------------------|-----------------|------------------|
| (d)  | (d)              | (m <sup>3</sup> /s)      | (m <sup>3</sup> /s)  | (%)                | ( $\eta_{Turb}$ )     | (m)  | ( $\eta_{ges}$ )    | (kW)            | (kWh)            |
| 0    |                  | 0.0                      |                      | 0%                 |                       | 40.0 | 0.00                | 0               | 0                |
| 1    | 1                | 0.0                      |                      | 0%                 |                       | 40.0 | 0.00                | 0               | 0                |
| 2    | 1                | 0.1                      |                      | 0%                 |                       | 40.0 | 0.00                | 0               | 0                |
| 3    | 1                | 0.1                      |                      | 0%                 |                       | 40.0 | 0.00                | 0               | 0                |
| 4    | 1                | 0.1                      |                      | 0%                 |                       | 40.0 | 0.00                | 0               | 0                |
| 5    | 1                | 0.1                      |                      | 0%                 |                       | 40.0 | 0.00                | 0               | 0                |
| 6    | 1                | 0.1                      |                      | 0%                 |                       | 40.0 | 0.00                | 0               | 0                |
| 7    | 1                | 0.1                      |                      | 0%                 |                       | 40.0 | 0.00                | 0               | 0                |
| 8    | 1                | 0.1                      |                      | 0%                 |                       | 40.0 | 0.00                | 0               | 0                |
| 9    | 1                | 0.1                      |                      | 0%                 |                       | 40.0 | 0.00                | 0               | 0                |
| 10   | 1                | 0.2                      |                      | 0%                 |                       | 40.0 | 0.00                | 0               | 0                |
| 15   | 5                | 0.3                      |                      | 0%                 |                       | 40.0 | 0.00                | 0               | 0                |
| 20   | 5                | 0.4                      | 0.40                 | 14%                | 0.80                  | 40.0 | 0.72                | 113             | 13,593           |
| 25   | 5                | 0.7                      | 0.70                 | 25%                | 0.83                  | 40.0 | 0.75                | 206             | 24,680           |
| 30   | 5                | 0.8                      | 0.80                 | 28%                | 0.83                  | 40.0 | 0.75                | 235             | 28,205           |
| 40   | 10               | 1.0                      | 1.00                 | 35%                | 0.86                  | 40.0 | 0.78                | 304             | 73,062           |
| 50   | 10               | 1.2                      | 1.20                 | 42%                | 0.86                  | 40.0 | 0.78                | 365             | 87,675           |
| 60   | 10               | 1.4                      | 1.40                 | 49%                | 0.86                  | 40.0 | 0.78                | 426             | 102,287          |
| 70   | 10               | 1.7                      | 1.70                 | 60%                | 0.86                  | 40.0 | 0.78                | 518             | 124,206          |
| 80   | 10               | 2.0                      | 2.00                 | 71%                | 0.86                  | 40.0 | 0.78                | 609             | 146,125          |
| 90   | 10               | 2.4                      | 2.40                 | 85%                | 0.86                  | 40.0 | 0.78                | 731             | 175,350          |
| 100  | 10               | 2.7                      | 2.70                 | 95%                | 0.86                  | 40.0 | 0.78                | 822             | 197,268          |
| 110  | 10               | 3.2                      | 2.83                 | 100%               | 0.86                  | 40.0 | 0.78                | 862             | 206,766          |
| 120  | 10               | 3.7                      | 2.83                 | 100%               | 0.86                  | 40.0 | 0.78                | 862             | 206,766          |
| 130  | 10               | 4.3                      | 2.83                 | 100%               | 0.86                  | 40.0 | 0.78                | 862             | 206,766          |
| 150  | 20               | 5.3                      | 2.83                 | 100%               | 0.86                  | 40.0 | 0.78                | 862             | 413,533          |
| 183  | 33               | 7.3                      | 2.83                 | 100%               | 0.86                  | 40.0 | 0.78                | 862             | 682,329          |
| 210  | 27               | 9.3                      | 2.83                 | 100%               | 0.86                  | 40.0 | 0.78                | 862             | 558,269          |
| 240  | 30               | 12.0                     | 2.83                 | 100%               | 0.86                  | 40.0 | 0.78                | 862             | 620,299          |
| 270  | 30               | 15.5                     | 2.83                 | 100%               | 0.86                  | 40.0 | 0.78                | 862             | 620,299          |
| 300  | 30               | 20.5                     | 2.83                 | 100%               | 0.86                  | 40.0 | 0.78                | 862             | 620,299          |
| 320  | 20               | 26.2                     | 2.83                 | 100%               | 0.86                  | 40.0 | 0.78                | 862             | 413,533          |
| 330  | 10               | 28.8                     | 2.83                 | 100%               | 0.86                  | 40.0 | 0.78                | 862             | 206,766          |
| 340  | 10               | 34.0                     | 2.83                 | 100%               | 0.86                  | 40.0 | 0.78                | 862             | 206,766          |
| 350  | 10               | 42.7                     | 2.83                 | 100%               | 0.86                  | 40.0 | 0.78                | 862             | 206,766          |
| 356  | 6                | 56.0                     | 2.83                 | 100%               | 0.86                  | 40.0 | 0.78                | 862             | 124,060          |
| 357  | 1                | 56.0                     | 2.83                 | 100%               | 0.86                  | 40.0 | 0.78                | 862             | 20,677           |
| 358  | 1                | 56.0                     | 2.83                 | 100%               | 0.86                  | 40.0 | 0.78                | 862             | 20,677           |
| 359  | 1                | 56.0                     | 2.83                 | 100%               | 0.86                  | 40.0 | 0.78                | 862             | 20,677           |
| 360  | 1                | 72.2                     | 2.83                 | 100%               | 0.86                  | 40.0 | 0.78                | 862             | 20,677           |
| 361  | 1                | 72.2                     | 2.83                 | 100%               | 0.86                  | 40.0 | 0.78                | 862             | 20,677           |
| 362  | 1                | 72.2                     | 2.83                 | 100%               | 0.86                  | 40.0 | 0.78                | 862             | 20,677           |
| 363  | 1                | 72.2                     | 2.83                 | 100%               | 0.86                  | 40.0 | 0.78                | 862             | 20,677           |
| 364  | 1                | 600.8                    | 2.83                 | 100%               | 0.86                  | 40.0 | 0.78                | 862             | 20,677           |

 **$\Sigma$  Annual output: 6,431,082** **$\Sigma$  Annual output incl. standstill: 6,109,528**

10/09/2009

## Appendix 2

**Economic analysis using dynamic amortisation method**

Project: Manuherikia River near Chatto Creek

**Input data:**

|                            |                |
|----------------------------|----------------|
| CAPEX (investment costs) : | 3,260,000 NZ\$ |
| Proprietary capital:       | 0 NZ\$         |
| OPEX p.a.:                 | 20,000 NZ\$    |
| Annual energy output:      | 6,200,000 kWh  |
| Compensation:              | 0.05 NZ\$/kWh  |
| Discount rate:             | 8.0 %          |

**Calculation:**

|                                      |              |
|--------------------------------------|--------------|
| Revenue p.a.:                        | 310,000 NZ\$ |
| Net revenue p.a. (= revenue - OPEX): | 290,000 NZ\$ |

| End year | Net payment<br>(NZ\$) | Discounting<br>rate | Discounted net<br>revenue<br>(NZ\$) | Cumulated<br>net revenue<br>(NZ\$) |
|----------|-----------------------|---------------------|-------------------------------------|------------------------------------|
| 0        | -3,260,000            | 1.0000              | -3,260,000                          | -3,260,000                         |
| 1        | 290,000               | 0.9259              | 268,519                             | -2,991,481                         |
| 2        | 290,000               | 0.8573              | 248,628                             | -2,742,853                         |
| 3        | 290,000               | 0.7938              | 230,211                             | -2,512,642                         |
| 4        | 290,000               | 0.7350              | 213,159                             | -2,299,483                         |
| 5        | 290,000               | 0.6806              | 197,369                             | -2,102,114                         |
| 6        | 290,000               | 0.6302              | 182,749                             | -1,919,365                         |
| 7        | 290,000               | 0.5835              | 169,212                             | -1,750,153                         |
| 8        | 290,000               | 0.5403              | 156,678                             | -1,593,475                         |
| 9        | 290,000               | 0.5002              | 145,072                             | -1,448,403                         |
| 10       | 290,000               | 0.4632              | 134,326                             | -1,314,076                         |
| 11       | 290,000               | 0.4289              | 124,376                             | -1,189,700                         |
| 12       | 290,000               | 0.3971              | 115,163                             | -1,074,537                         |
| 13       | 290,000               | 0.3677              | 106,632                             | -967,905                           |
| 14       | 290,000               | 0.3405              | 98,734                              | -869,171                           |
| 15       | 290,000               | 0.3152              | 91,420                              | -777,751                           |
| 16       | 290,000               | 0.2919              | 84,648                              | -693,103                           |
| 17       | 290,000               | 0.2703              | 78,378                              | -614,725                           |
| 18       | 290,000               | 0.2502              | 72,572                              | -542,153                           |
| 19       | 290,000               | 0.2317              | 67,196                              | -474,956                           |
| 20       | 290,000               | 0.2145              | 62,219                              | -412,737                           |
| 21       | 290,000               | 0.1987              | 57,610                              | -355,127                           |
| 22       | 290,000               | 0.1839              | 53,343                              | -301,784                           |
| 23       | 290,000               | 0.1703              | 49,391                              | -252,393                           |
| 24       | 290,000               | 0.1577              | 45,733                              | -206,660                           |
| 25       | 290,000               | 0.1460              | 42,345                              | -164,315                           |
| 26       | 290,000               | 0.1352              | 39,209                              | -125,106                           |
| 27       | 290,000               | 0.1252              | 36,304                              | -88,802                            |
| 28       | 290,000               | 0.1159              | 33,615                              | -55,187                            |
| 29       | 290,000               | 0.1073              | 31,125                              | -24,062                            |
| 30       | 290,000               | 0.0994              | 28,819                              | 4,757                              |

|                        |               |             |             |             |
|------------------------|---------------|-------------|-------------|-------------|
| <b><u>Summary:</u></b> | Discount rate | 0.04 \$/kWh | 0.05 \$/kWh | 0.06 \$/kWh |
|                        | 5.0           | 3,500,000   | 4,460,000   | 5,410,000   |
|                        | 6.0           | 3,140,000   | 3,990,000   | 4,850,000   |
|                        | 7.0           | 2,830,000   | 3,600,000   | 4,370,000   |
|                        | 8.0           | 2,570,000   | 3,260,000   | 3,960,000   |
|                        | 9.0           | 2,340,000   | 2,980,000   | 3,620,000   |
|                        | 10.0          | 2,150,000   | 2,730,000   | 3,320,000   |

10/09/2009

